

LA-9674-MS

CIC-14 REPORT COLLECTION  
REPRODUCTION  
COPY

Los Alamos National Laboratory is operated by the University of California for the United States Department of Energy under contract W-7405-ENG-36.

*Present Status of Plutonium Metal Production  
and Purification at Los Alamos - 1982*



**Los Alamos** Los Alamos National Laboratory  
Los Alamos, New Mexico 87545

This work was supported by the US Department of Energy, Weapons Production Division.

DISCLAIMER

This report was prepared as an account of work sponsored by an agency of the United States Government. Neither the United States Government nor any agency thereof, nor any of their employees, makes any warranty, express or implied, or assumes any legal liability or responsibility for the accuracy, completeness, or usefulness of any information, apparatus, product, or process disclosed, or represents that its use would not infringe privately owned rights. Reference herein to any specific commercial product, process, or service by trade name, trademark, manufacturer, or otherwise, does not necessarily constitute or imply its endorsement, recommendation, or favoring by the United States Government or any agency thereof. The views and opinions of authors expressed herein do not necessarily state or reflect those of the United States Government or any agency thereof.

LA-9674-MS

UC-10

Issued: June 1983

# Present Status of Plutonium Metal Production and Purification at Los Alamos—1982

D. C. Christensen  
L. J. Mullins



**Los Alamos** Los Alamos National Laboratory  
Los Alamos, New Mexico 87545

## CONTENTS

ABSTRACT . . . . .	1
I. INTRODUCTION . . . . .	1
II. MAIN PROCESS SEQUENCE FOR CONVERSION OF PLUTONIA TO HIGH-PURITY METAL . . . . .	4
A. Process Schematic . . . . .	4
B. Direct Oxide Reduction (DOR) . . . . .	4
C. Plutonium Tetrafluoride Production and Reduction . . . . .	6
D. Molten-Salt Extraction . . . . .	6
E. Ingot Casting . . . . .	9
F. Plutonium Electrorefining . . . . .	11
III. PRESENT PLUTONIUM RESIDUE RECYCLE . . . . .	15
A. Process Schematic . . . . .	15
B. Casting Skull Recycle (Burned Skull) . . . . .	15
C. Slag Recovery . . . . .	16
D. Molten-Salt Extraction--Salt Stripping . . . . .	17
E. Electrorefining Salt Stripping . . . . .	17
IV. PROPOSED PLUTONIUM RECYCLE . . . . .	18
A. Process Schematic . . . . .	18
B. Molten-Salt Extraction Salts: Plutonium and Americium Recovery . . . . .	19
C. Anode Residue Recovery . . . . .	19
V. PROPOSED REAGENT RECYCLE . . . . .	21
A. Process Schematic . . . . .	21
B. Direct Oxide Reduction (DOR) . . . . .	22
C. Molten-Salt Extraction Salt Recycle and Electrorefining Salt Recycle . . . . .	23
VI. SUMMARY . . . . .	24
A. Processing Status . . . . .	24
B. The Future Process Goal . . . . .	25
REFERENCES . . . . .	25

PRESENT STATUS OF PLUTONIUM METAL  
PRODUCTION AND PURIFICATION AT LOS ALAMOS--1982

by

D. C. Christensen and L. J. Mullins

ABSTRACT

The production of plutonium metal by both fluoride and oxide reduction is well established at Los Alamos. The subsequent purification of this metal by electrorefining is now being performed on a production basis on a 6-kg batch scale. The objective is the production of high-purity plutonium metal.

Recent process development efforts have been devoted to more expeditious and less costly pyrochemical reprocessing of residues created by the metal preparation and purification process. The objective here is to establish an internal recycle that yields either reusable or discardable residues and recovers all plutonium for feed to the electrorefining purification system. This internal recycle is to be performed in a more timely and less costly operation than it is in the present reprocess mode.

---

I. INTRODUCTION

The pyrochemical processing of plutonium salts, oxides, and metals is well established at Los Alamos. The Laboratory has had a very active program for the production of high-purity plutonium metal for both Laboratory and national needs for many years.

Plutonium pyrochemistry at Los Alamos dates back to 1956. During the period 1956-1962, the Plutonium Chemistry and Metallurgy group was involved in a program on the pyrochemical processing of Plutonium Fast Breeder Reactor Fuels for the Los Alamos Molten Plutonium Reactor Experiment (LAMPRE). Processes such as oxidative slagging, halide slagging, pyroredox, liquation, and electrorefining (ER) were spawned in this period. These processes were turned toward national defense programs in 1964. In 1976, direct oxide reduction (DOR) was developed in support of the  $^{238}\text{Pu}$  artificial heart program. In 1978 the DOR process was

adopted for use in  $^{239}\text{Pu}$  programs. This operation gave us two principal processes for making plutonium metal:

1. the conventional  $\text{PuF}_4$  reduction process and
2. direct oxide reduction (DOR) process.

In addition, there are two principal metal purification processes:

1. electrorefining (ER) and
2. halide slagging or molten salt extraction (MSE).

Beginning in 1978, the above four processes were put into a production mode in the new TA-55 building at Los Alamos. The source of plutonium for Los Alamos needs was plutonium dioxide from aqueous-recovery processes and metal from fabrication scrap. In 1980 Los Alamos embarked on a program to increase the output of pure metal.<sup>1</sup> Pyrochemical processes were selected as the candidate operations to achieve the increased throughput rapidly and cost effectively. This type of processing offers the potential of large cost reduction over traditional aqueous-chemical processes for a number of reasons.

- The processes conserve expensive floor space because of their highly compact process hardware. Both the plutonium and the reagents are processed in their highest density form (liquid).
- Very few steps are needed in order to achieve highly purified products. (See Fig. 1).
- Primary-waste generation is small because of the high-density nature of the fused-salt operations. Nearly all primary-waste residues show excellent potential for reagent recycle. (At present, the main processing sequence for plutonium processing does not include significant reagent and residue recycle.)
- Secondary-waste volume from the processing of waste materials is minimal.
- The turnaround time for plutonium in residues is very rapid.

The increased throughput resulted in a commensurate increase in primary-residue generation. The increased production of plutonium metal was achieved very easily in existing floor space because of the compact nature of equipment, but the increased needs for aqueous residue handling could not be met with existing floor space and processing capacity. As a result, the residues were stored for future processing. In order to support the process scale-up, R&D efforts have been put into place with the goal of developing cost-effective and high-throughput pyrochemical processes for handling process materials and residues.

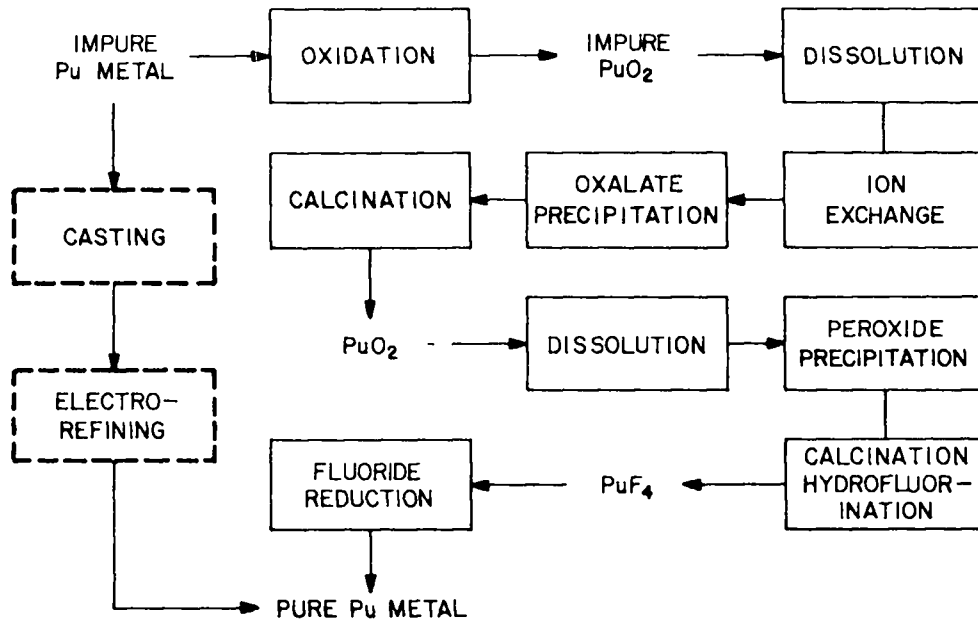

Fig. 1. Pyrochemical vs aqueous flowsheet for metal purification.

In addition, problems in the areas of process and equipment design have been evaluated. R&D efforts are also being turned to tackle these problem areas. Most recent efforts are primarily concerned with the recovery of plutonium values in the residues and the recycle of these waste streams back into the main process sequence.

This document will summarize our present main production sequence and discuss how it was arrived at. It will then discuss the status of our present recycle of plutonium values in residues. Third, it will discuss our proposed recycle of all plutonium in residues. Finally, it will discuss our goal of a fully integrated process sequence where our plutonium and salt residues are recycled through the production sequence.

## II. MAIN PROCESS SEQUENCE FOR CONVERSION OF PLUTONIA TO HIGH-PURITY METAL

### A. Process Schematic

A schematic of the main process sequence for the conversion of plutonia scrap to high-purity metal is shown in Fig. 2. Plutonia scrap is fed to both the DOR process and the plutonium tetrafluoride production/reduction process.

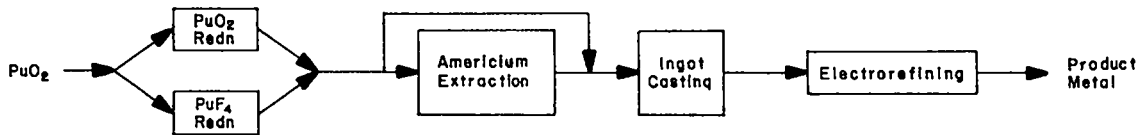
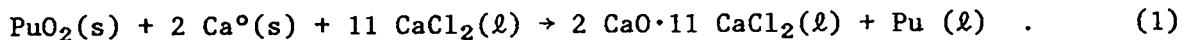

Fig. 2. Main production sequence.

### B. Direct Oxide Reduction (DOR)

In DOR, plutonia is reacted with calcium metal to form plutonium metal and calcium oxide. (A thorough review of the DOR process is found in Refs. 1 and 2.) The reaction takes place in a CaCl<sub>2</sub> solvent that dissolves the calcium oxide and allows the plutonium metal to coalesce in the bottom of the crucible. The reaction is as follows:



The DOR equipment is shown in Fig. 3. The reduction is performed in a magnesia crucible. The reactants are loaded into the crucible and heated by a clam-shell resistance furnace to 800°C. Once the CaCl<sub>2</sub> is molten, a Ta-10W stirrer and a Ta-Ni thermocouple sheath are lowered into the melt. Stirring is commenced. The reaction is monitored with a thermocouple. Once the reaction is complete



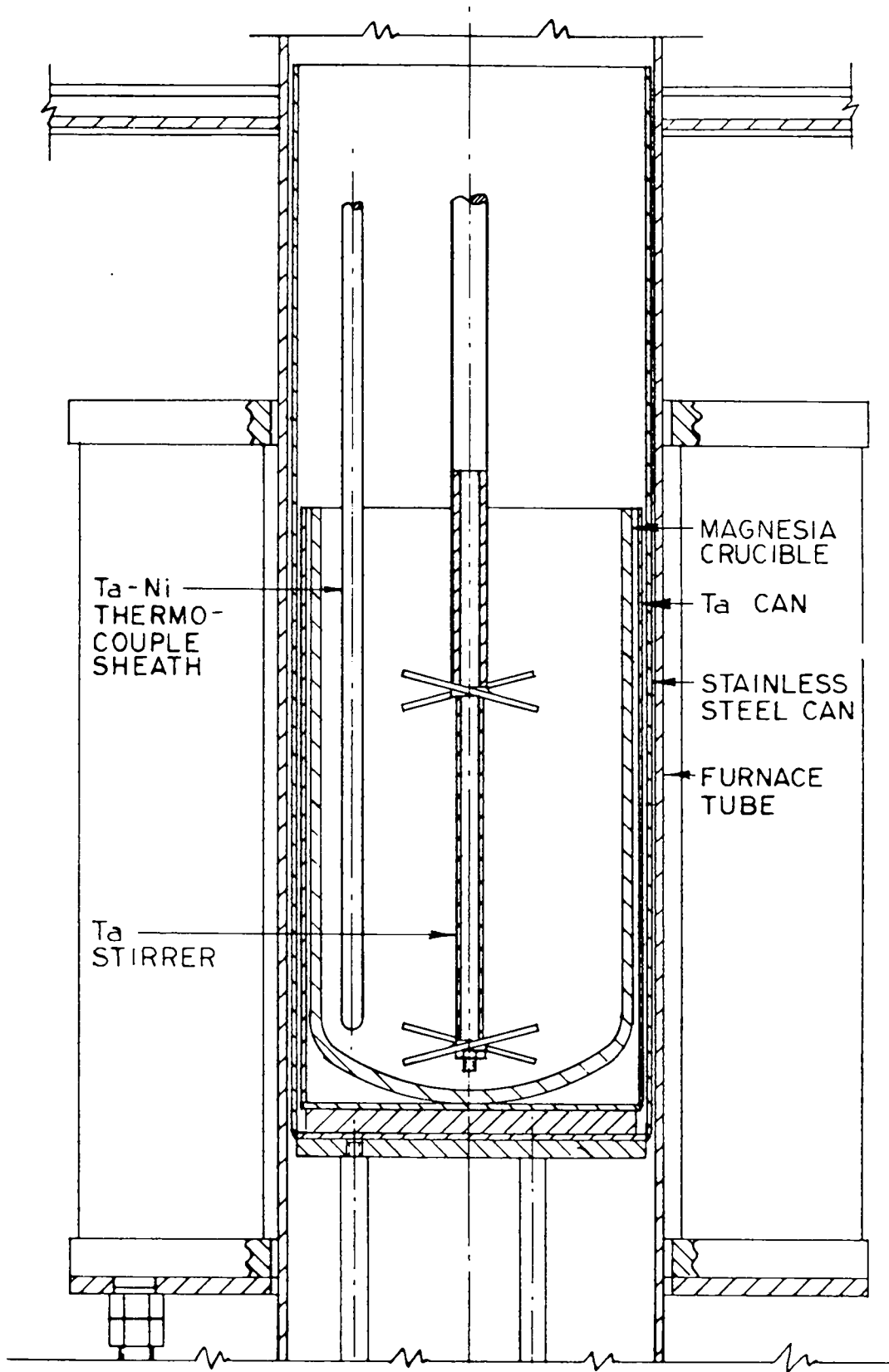

Fig. 3. DOR equipment.

(approximately 2 minutes), the stirrer and thermocouple well are retracted and the melt is allowed to cool. Fig. 4 shows a typical DOR product and salt/crucible residue. A typical product button weighs 600 g and the process yield is >99%. Essentially no purification takes place in the reduction step, meaning that the product button is no purer than the feed oxide.

### C. Plutonium Tetrafluoride Production and Reduction

In  $\text{PuF}_4$  production/reduction, plutonia is fed first to an HF reaction furnace where the  $\text{PuO}_2$  is converted to  $\text{PuF}_4$ . The  $\text{PuF}_4$  is reacted with calcium metal in the presence of iodine to form plutonium metal,  $\text{CaF}_2$ , and  $\text{CaI}_2$ . (A review of the  $\text{PuF}_4$  production/reduction process is found in Refs. 1 and 3-5.) During the process, calcium and iodine react first to initiate the plutonium reaction. The  $\text{PuF}_4$  and calcium then react to form plutonium metal and  $\text{CaF}_2$ . Both the iodine and  $\text{PuF}_4$  reactions with calcium are very exothermic and provide enough heat to melt the waste slag and allow the plutonium metal to coalesce in the bottom of the crucible. The reactions are as follows:

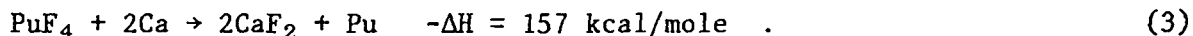
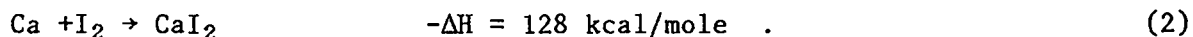

Figure 5 shows a typical  $\text{PuF}_4$  product button with the slag by-product and crucible residue. A typical product button weighs 1250 g and the process yield is 96-98%. Essentially no purification takes place in the reduction step, which means that the product button is no purer than the feed fluoride.

### D. Molten-Salt Extraction

The metal from DOR and  $\text{PuF}_4$  reduction is impure and proceeds to the next step in the process sequence, americium extraction (more commonly referred to as MSE). This process is specifically designed to reduce the americium content of the plutonium metal. (Americium-241 spontaneously grows into plutonium as a result of plutonium-241 decay.) When the impure metal contains more than 1000 ppm of americium, it is run through the MSE process. Otherwise, it by-passes the MSE step and proceeds directly to ER.

The MSE process was first reported in Ref. 6 as the halide- or chloride-slugging process. It was later optimized and developed into a major production process by workers at Rocky Flats Plant.<sup>7</sup> In our process, the feed metal is



Fig. 4. DOR metal product with residues.



placed in a magnesia crucible. The extraction process is performed in the identical equipment shown in Fig. 3. The extraction procedure is essentially identical to the DOR procedure except that the stirring cycle lasts 30 minutes instead of only a few minutes. A low-melting eutetic salt, made up of KCl and NaCl, is used as a bulk matrix for the americium reaction. The oxidizing agent typically used is  $\text{MgCl}_2$  although  $\text{PuF}_4$  has been extensively used at Los Alamos. The reactions are as follows:

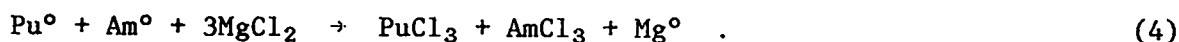

or



The extent of the first reaction is about 67%, which means that some of the  $\text{MgCl}_2$  remains in the bulk salt. In a typical 4.5-kg run containing 3000 ppm americium, 90% of the americium is oxidized at the expense of approximately 200 g plutonium. Therefore, a typical product weighs 4400 g and contains 98% of the feed plutonium. The process is very effective for reducing the americium content without sacrificing large amounts of plutonium to salt residues.

#### E. Ingot Casting

After the reduction of the americium content in the impure metal, the metal must be put into a shape that is compatible with the ER cell. This requires alloying and casting the metal into a cylindrical ingot shape. Casting therefore, is the next step in the main process sequence.

The shape of the ingot is a 7.3-cm-diam cylinder, which is up to 10 cm long. The quantity of metal needed for ER is 6 kg. Because of nuclear criticality concerns, 6 kg of  $\alpha$ -phase (or near full density) metal could not be allowed in the cylindrical configuration. (For an explanation of criticality concerns with respect to the 6-kg ER process, see Ref. 1). As a result of the criticality constraints, the metal is alloyed with gallium during the casting phase in order to change the bulk density from  $>19 \text{ g/cm}^3$  down to  $<16.5 \text{ g/cm}^3$ . The ingot-casting step involves heating the metal buttons under a vacuum to above the metal melting point. The metal is mixed with the gallium and then bottom-poured from the furnace tube into the mold. A casting residue, or skull, always occurs. This skull contains any light-element impurities, oxide films, or high-melting contaminants that exist in the impure-metal buttons. The casting yield is typically 95%. A typical ingot can be seen in Fig. 6.



Fig. 6. Impure-metal ingot feed for ER.

## F. Plutonium ER

Plutonium ER principles are summarized in Refs. 2 and 8-9. Briefly, the process consists of oxidizing plutonium from an impure-metal feed at the anode and reducing it to pure metal at the cathode.

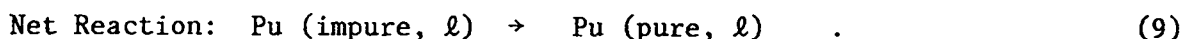
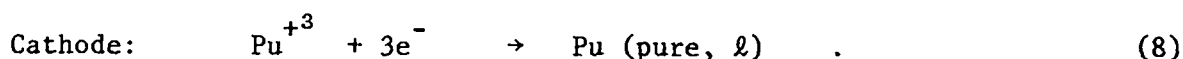
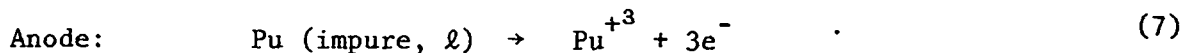

The process is done at 740°C in a molten salt consisting of NaCl-KCl-MgCl<sub>2</sub>, under near-equilibrium conditions. Virtually all of the impurities concentrate in the anode. Of the impurities usually present in plutonium, only americium concentrates in the salt.

The ER equipment is shown in Fig. 7. The process is performed in a double-cupped-vitrified, magnesia crucible. The inner cup contains the impure metal feed ingot. The crucible is placed inside a tantalum safety can and placed inside the furnace tube. The assembly is heated by a resistance furnace. The schematic in Fig. 8 shows the cell in operation. Both the impure metal and the molten-salt electrolyte are stirred by a vitrified magnesia stirrer. A tungsten rod is suspended in the impure-metal pool to serve as the anode rod. The anode rod is electrically insulated from the salt by a magnesia sleeve. A cylindrical-shaped sheet of tungsten is suspended in the annular space between the two cups and serves as the cathode. It is this annular space that is the product collection zone in the crucible.

The molten salt referred to in Fig. 8 is equal molar NaCl·KCl. A small amount of MgCl<sub>2</sub> is added to this salt as an oxidizing agent. The MgCl<sub>2</sub> reacts with the impure metal both to charge the salt with Pu<sup>+3</sup> and to remove some additional americium from the metal. (See Equations 4-6.) The actual ER process is accomplished by stirring at 800 rpm and passing a dc current between anode and cathode. Plutonium oxidizes at the anode and reduces back to metal at the cathode. The metal drips off the cathode and into the annular space. Fig. 9 shows a typical product ring after breakout. The product yield from a Pu-1 wt% Ga alloy is 83%. Approximately 10% of the residual plutonium remains in the anode as a very impure heel. The remaining plutonium (~7%) ends up in the slag as either uncoalesced metal shot or as Pu<sup>+3</sup> chloride salt.

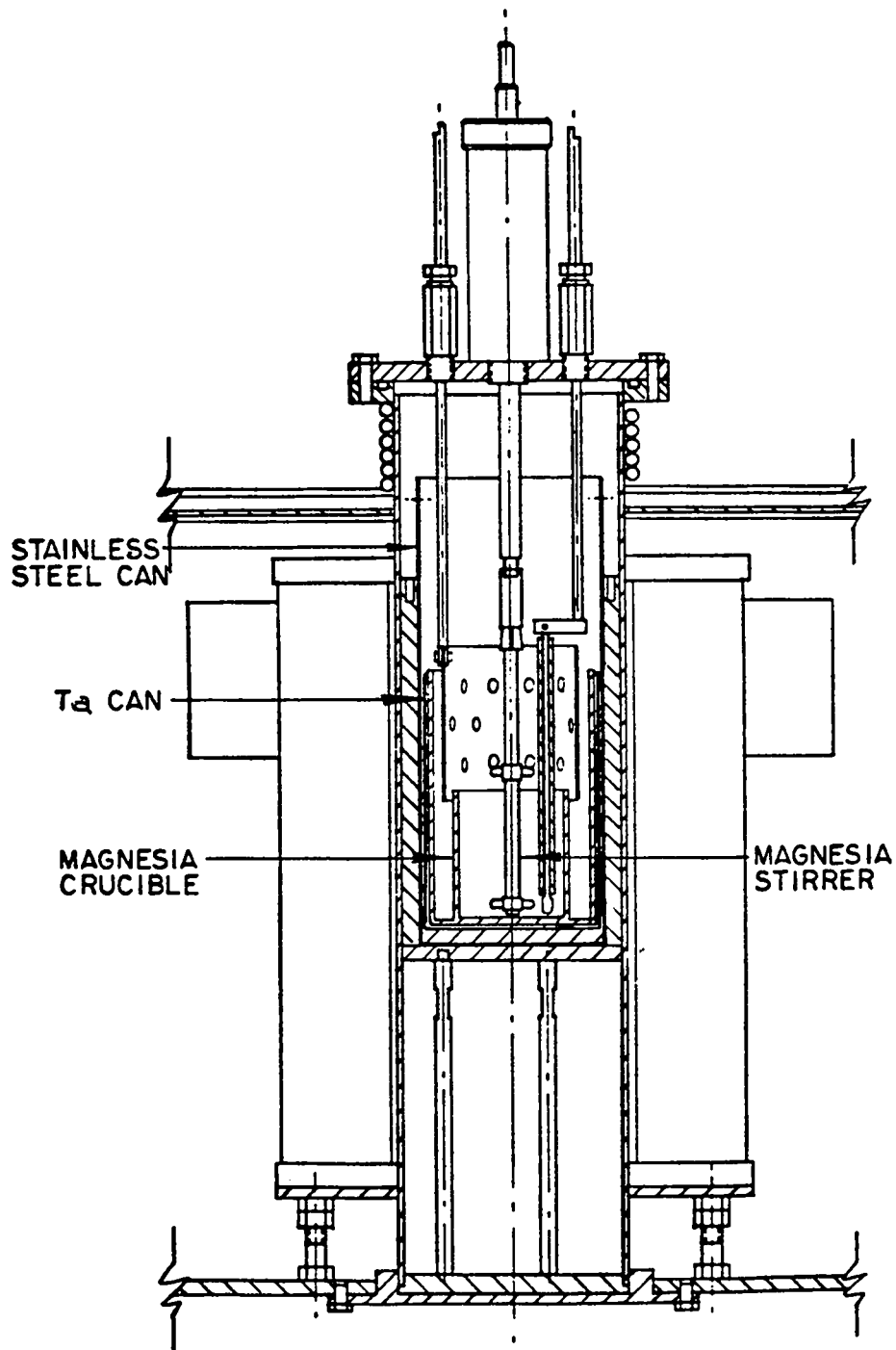

Fig. 7. ER process equipment.



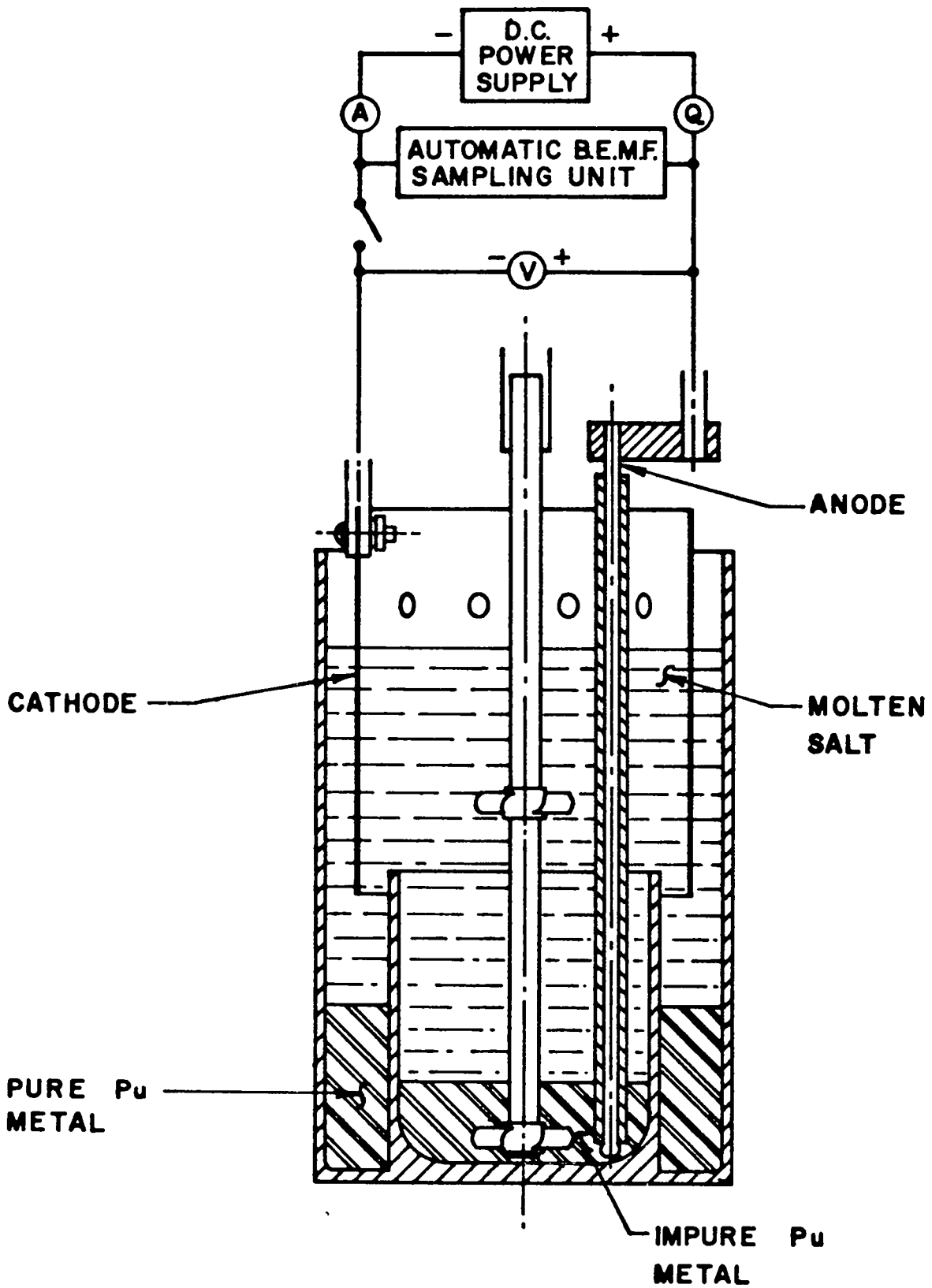

Fig. 8. Schematic of electrorefining.

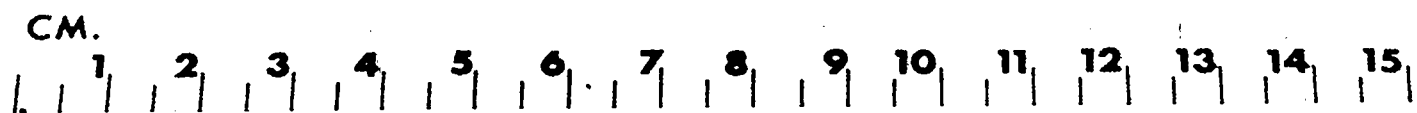
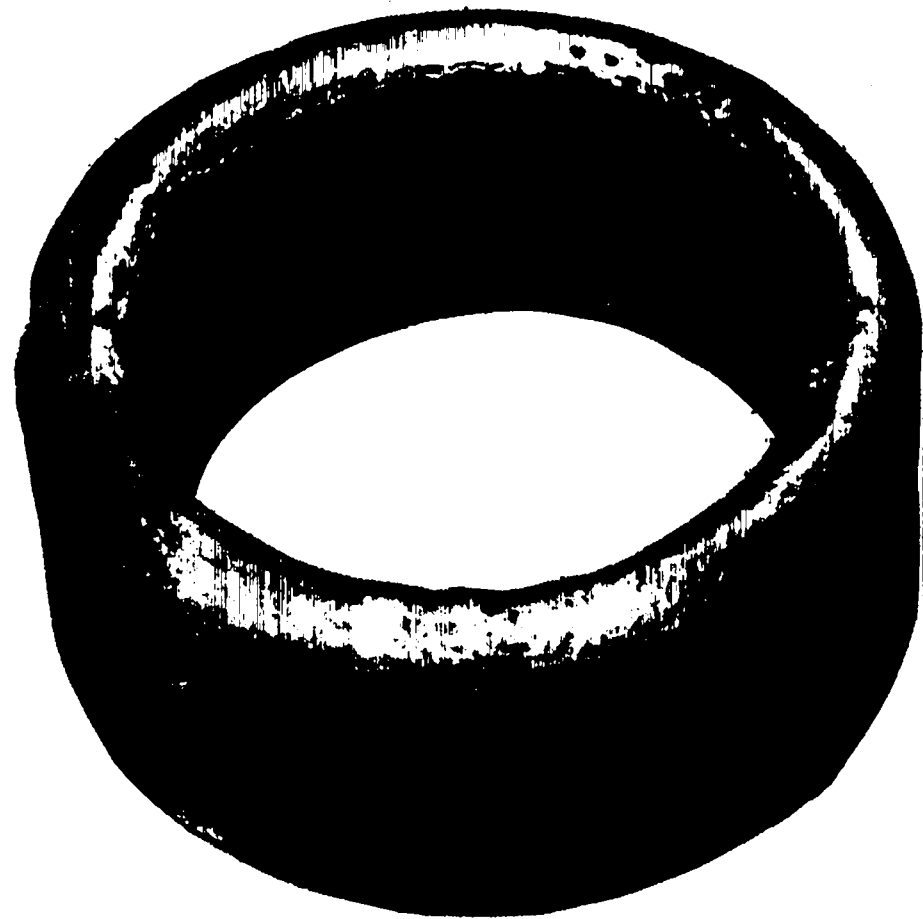

Fig. 9. Typical ER product ring.

### III. PRESENT PLUTONIUM RESIDUE RECYCLE

#### A. Process Schematic

A schematic showing our main production sequence and our present plutonium residue recycle streams is seen in Fig. 10. There are four principal recycle streams in active use:

1. casting skull recycle (burned skull),
2. slag recovery,
3. molten-salt extraction--salt stripping,
4. electrorefining salt stripping.

Each of these four streams will be discussed in more depth.

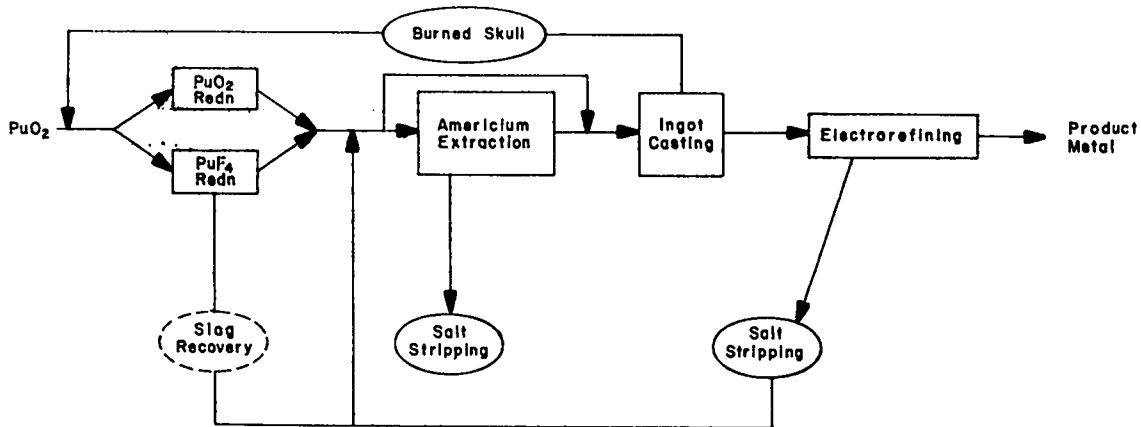

Fig. 10. Main production sequence plus present plutonium residue recycle.

#### B. Casting Skull Recycle (Burned Skull)

In the ingot-casting step, a casting residue occurs, which is called the skull. The casting yield is typically  $\geq 95\%$  meaning that up to 5% of the plutonium remains in the skull.

Usually the metal buttons fed to the casting operations retain some of the calcium used in the reduction operation. This calcium exists either as a film

on the button or as a number of small inclusions inside the button. During the casting step, this material vaporizes off and is trapped in a cold zone of the furnace. This residue usually contains no plutonium and can be discarded.

In addition to the calcium film, the buttons usually have a film of  $\text{PuO}_2$  as a result of exposure to glove box air. Upon casting, this  $\text{PuO}_2$  floats and remains in the skull along with trapped plutonium metal. It is this portion of the skull that is recycled back into the production sequence.

The skull metal and oxide are first completely burned to  $\text{PuO}_2$ . This is accomplished simply by heating the skull in air to 400-500°C. The plutonium metal spontaneously burns and is collected as a green  $\text{PuO}_2$  powder. A number of batches of burned skull are combined into a single batch and recycled back to feed for DOR. This process is normally 100% efficient with only a small plutonium residue showing up in items such as clean-up rags.

### C. Slag Recovery

An in-depth discussion on the slag-recovery process is found in Ref. 10. A brief review follows.

Periodically, during the  $\text{PuF}_4$  reduction process, production misfires occur. The misfires are caused by a number of things. The essence of the misfire is that not enough heat is generated during the reduction to melt the  $\text{CaF}_2$  by-product. As a result, the plutonium metal remains trapped in the  $\text{CaF}_2$  slag and does not flow to the bottom of the crucible and coalesce as a metal button.

In an effort to rapidly recover the plutonium from these residues, a process was developed whereby the  $\text{CaF}_2$  slag is dissolved in  $\text{CaCl}_2$  at 685°C. The plutonium, which exists either as a finely divided metal fog or as an incompletely reduced fluoride salt, is reduced to metal and/or allowed to coalesce as a button in the bottom of the crucible. The process has been demonstrated on slags containing between 250 and 1000 g of plutonium, but it is not restricted to these high-plutonium-bearing residues. The recovery of plutonium in a 1-day cycle has averaged 96%. All of the resulting residues have fallen below our allowable discard limits and have been sent to 20-yr retrievable storage.

This process is presently being used for treating the misfired slags only. In the fluoride-reduction process, approximately 85% of all slags are discardable to 20-yr retrievable storage. The remaining 15% (representing approximately six slags per month) contain approximately 100 g of plutonium, each. Because of the small quantity of plutonium and the shortage of processing space, these slags are

not routinely recovered pyrochemically. If the slags contain >250 g of plutonium, they are recovered pyrochemically. Future planning will provide for routine recovery of all waste slags.

#### D. Molten-Salt Extraction--Salt Stripping

The salt residue from the americium extraction process is made up of an equimolar KCl·NaCl salt mix, MgCl<sub>2</sub>, PuCl<sub>3</sub>, and AmCl<sub>3</sub>. A typical residue will weigh approximately 2.0 kg and contain 200 g plutonium and 10-20 g americium. The remaining weight is essentially all KCl·NaCl with approximately 50 g of MgCl<sub>2</sub>.

The equipment proposed for use in the salt-recovery step is identical to that used in the DOR process (Fig. 3). The proposed process is to be performed inside an MgO crucible at 800°C. A Ta-10W stirrer will be used to mix the reactants. The salt-recovery operation will consist of melting the salt and contacting it with calcium metal. The calcium metal reduces the PuCl<sub>3</sub> and AmCl<sub>3</sub> to the metal form. The magnesium metal vaporizes because of its high vapor pressure at the 800°C operating temperature. The plutonium and americium should coalesce as a button in the bottom of the crucible.

Only a few preliminary tests have been run previously. No definitive results can be concluded at this time. We have successfully removed the plutonium from the salt residue. The exact disposition of the americium is not clear. Thermodynamically, all of the americium should be reduced to metal and recovered with the plutonium. Our first indications are that some americium is removed with the plutonium, but that some stays behind in the salt and calcium residue.

The stripping approach seems to be practical. Future work will investigate the disposition of the americium. In addition, work will be done to establish proper operating conditions and optimize process yields.

#### E. Electrorefining Salt Stripping

Approximately 8% (500 g) of the plutonium in an ER run is lost to the salt phase. Before last year, this waste stream was recovered by aqueous processing.<sup>2</sup> The salts are now recovered pyrochemically by salt stripping. This operation consists simply of contacting the molten-salt residue with calcium metal. The calcium-metal addition causes the reduction of PuCl<sub>3</sub> to metal and the coalescence of metallic plutonium shot. The process results in the formation of a metallic plutonium button, a large white-salt phase, and a small black-salt phase. The plutonium metal is recycled to MSE and ER. The white-salt phase together with the

crucible contains less than recoverable amounts of plutonium and is discarded. The black-salt phase is combined with other black-salt phases and sent to DOR. Complete details of the process are given in Ref. 5.

#### IV. PROPOSED PLUTONIUM RECYCLE

##### A. Process Schematic

A schematic showing our main production sequence and residue-recycle streams is seen in Fig. 11. In addition, on this figure are two proposed streams which are under investigation but are not being used in the production sequence. They are

1. plutonium and americium recovery from MSE salt stripping product, and
2. ER anode recovery.

The goal of these two processes is to provide a closed loop on the plutonium streams in the metal preparation and purification sequence.

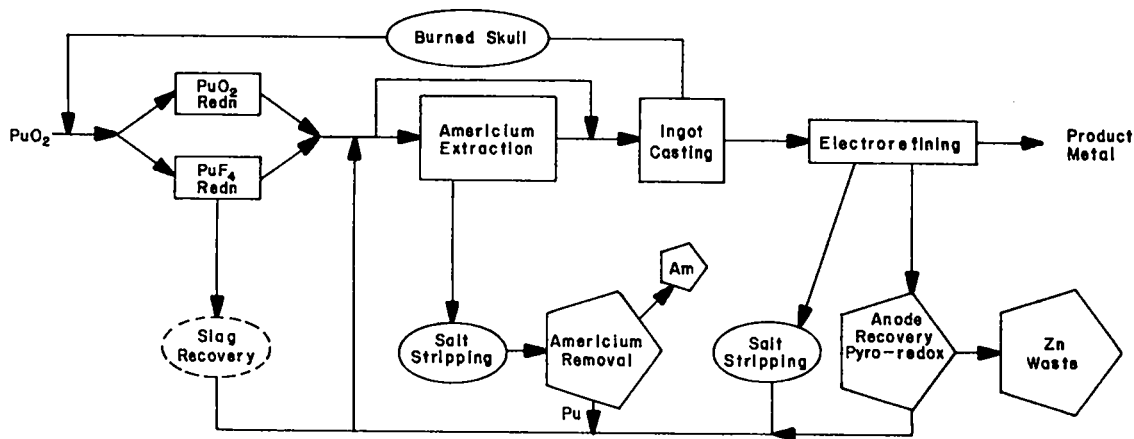

Fig. 11. Main production sequence, present plutonium residue recycle, plus proposed plutonium residue recycle.

## B. MSE Salts: Plutonium and Americium Recovery

We have demonstrated the ability to successfully strip both the plutonium and americium from the MSE salts. The resulting metal product now contains as much as 10% americium and as a result cannot be fed directly into the metal processing sequence. The challenge is to find a hole for the americium and return the plutonium to the main production sequence.

The most promising method is vacuum distillation of the americium away from the plutonium. This method was demonstrated by Berry et al.<sup>12</sup> In this work, the goal was to recover pure americium metal. They demonstrated the ability to recover >50 g batches of americium in a two-stage distillation that was >99% pure.

In the system discussed here, the goal is not necessarily to recover pure americium but rather to significantly reduce the americium content in the plutonium. In doing so, the plutonium must be conserved such that the americium stream contains an insignificant amount of plutonium.

The target for americium concentration in the plutonium is <1000 ppm. This means that a 100-fold reduction of americium concentration is necessary. The vacuum distillation system discussed above seems a likely candidate for this step.

## C. Anode Residue Recovery

Approximately 10% of the plutonium present in a Pu-1 wt% Ga ER feed ends up in the anode residue. This residue also contains most of the impurities that were present in the metal feed. The following pyrochemical processes have been considered for recovering plutonium from this residue:

- ER at temperatures above 1110°C.
- ER with a solid plutonium anode and a liquid plutonium cathode.
- pyroredox.

After a study of the three alternatives, we concluded that pyroredox offered the most promise for anode residue recovery. Pyroredox is a molten-salt process in which plutonium metal is oxidized chemically into the salt phase and then reduced chemically into the metal phase. Most of the impurities are not oxidized and remain in the metal residue. Thus, for a plutonium-gallium anode residual, the reactions would be

### Oxidation

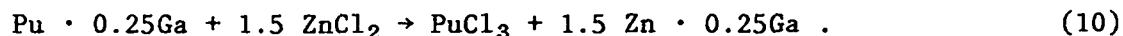

## Reduction



The pyroredox process has been studied extensively by workers at Argonne National Laboratory<sup>13</sup> and Rocky Flats.<sup>14</sup> Reavis et al., of Los Alamos National Laboratory, were apparently the first to explore the potential of pyroredox in 1961.<sup>15</sup> Knighton et al.<sup>16</sup>, of Rocky Flats, recently reported the results of a study in which 12 batches of impure plutonium metal (about 2 kg of plutonium per batch) were fed to the pyroredox process.<sup>14</sup> Processing was done in tungsten crucibles contained in tilt/pour furnaces. The oxidation and reduction reaction yields were excellent, averaging 99.77% and 99.17%, respectively. The overall process yield, however, was low, 89.97%, because of plutonium losses caused primarily by salt foaming. The purity of the plutonium metal product was poor because of entrainment of zinc metal in the salt phase. Knighton<sup>16</sup> concluded that the rate of oxidation must be slowed down or the rate of heat removal from the reaction site must be increased in order to control foaming. Although the percentage of zinc metal entrainment decreased from 27.3% for the first experiments to 13% for the last, the entrainment problem was not resolved. Thus, the two major pyroredox problems that Knighton identified were

1. foaming of salt, and
2. zinc metal entrainment in salt.

We believe that foaming can be eliminated by

1. controlling the rate of oxidation of plutonium by  $\text{ZnCl}_2$ ; i.e., by controlling the oxidation rate, we can control the temperature.
2. using pure, anhydrous reagents. (Note that in the DOR process, we have observed that wet  $\text{CaCl}_2$  results in salt foaming.)

Our experiments to date have been on the 100-g plutonium scale, and have been done in tantalum containers. They have demonstrated that

1. we can control the rate of oxidation of plutonium by reacting the molten  $\text{ZnCl}_2$  salt with a solid plutonium phase.
2. we can prepare and use anhydrous  $\text{ZnCl}_2$ -NaCl and  $\text{ZnCl}_2$ -KCl.
3. we can eliminate foaming.

We have not demonstrated quantitative phase separation of salt from metal in the oxidation step. Approximately 5% of the gallium was carried over from the Pu -1 wt% Ga feed to the product from the calcium reduction. The extent of purification gives us a workable process for pyroredox because the plutonium from the calcium reduction will be electrorefined.



We are now scaling up the 100-g experiments to plant-size equipment using magnesia crucibles for continuing studies. The equipment will be very similar to that used for DOR (Fig. 3).

## V. PROPOSED REAGENT RECYCLE

### A. Process Schematic

The final installations in our main production sequence will be the recycle of reagent salts. There are quite a number of options involved in recycling reagents from nearly every operation. Figure 12 shows the process schematic where the three major salt consumption steps are highlighted for potential recycle. The three steps are

1. DOR ( $\text{CaCl}_2$ ),
2. MSE,
3. ER.

These three processes all have unique problems in salt reuse. The recycle applications and reprocessing problems will be discussed in the following paragraphs.

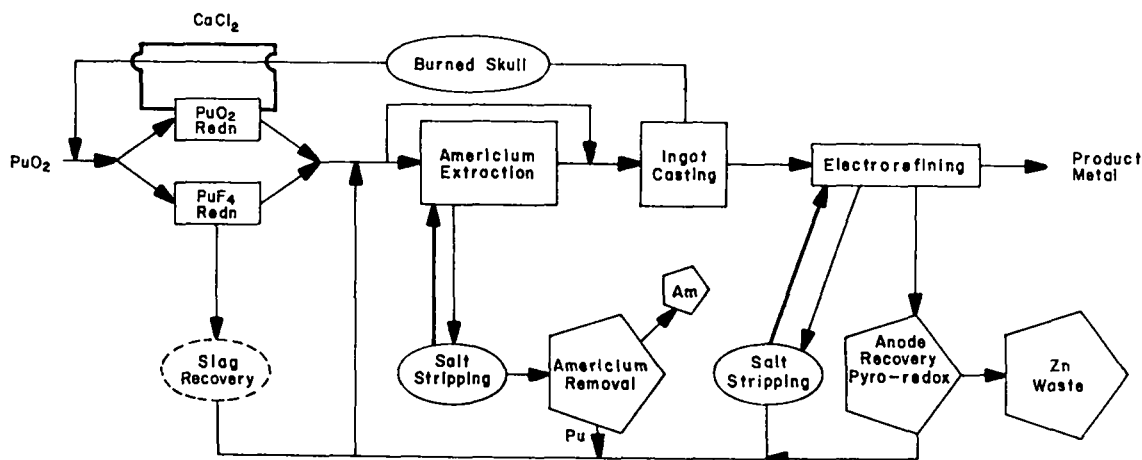
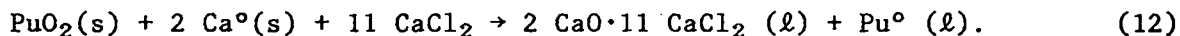

Fig. 12. Main production sequence, present plutonium residue recycle, proposed plutonium residue recycle, and proposed reagent recycle.

## B. Direct Oxide Reduction (DOR)

In DOR, calcium chloride is used as a solvent to soak up the calcium oxide by-product from the reduction reaction:



As can be seen, there are 11 moles of  $\text{CaCl}_2$  needed per mole of  $\text{PuO}_2$ . This amounts to a sizable quantity of salt for each reduction. A normal reduction involves 700 g of  $\text{PuO}_2$  and requires 3600 g of  $\text{CaCl}_2$ . The regeneration/reuse of the salt residue does more than just reduce the cost of  $\text{CaCl}_2$  for each reduction. The biggest area of impact is in waste handling and subsequent disposal.

The  $\text{CaO}$  by-product from the reduction has a very high melting point ( $2580^\circ\text{C}$ ). In order to coalesce the plutonium formed at  $800^\circ\text{C}$ , the  $\text{CaO}$  must remain in the liquid state. Hence, the need for the  $\text{CaCl}_2$  solvent.

In order to reuse the  $\text{CaO} \cdot \text{CaCl}_2$  salt cake, the  $\text{CaO}$  must be removed from the matrix, thus liberating a fresh  $\text{CaCl}_2$  solvent. There are three main mechanisms for achieving this:

1. physical separation of  $\text{CaO}$  from the  $\text{CaCl}_2$ ,
2. chemical conversion of  $\text{CaO}$  to  $\text{CaCl}_2$ , and
3. electrolytic removal of  $\text{CaO}$  from  $\text{CaCl}_2$ .

In physical separation, the goal is to find a solvent that can dissolve the  $\text{CaCl}_2$  and allow the  $\text{CaO}$  to settle. As it turns out  $\text{CaCl}_2$  is soluble in most alcohols and acetone, whereas  $\text{CaO}$  is essentially insoluble in both categories. After the  $\text{CaO}$  is separated, the alcohol could be evaporated to liberate  $\text{CaCl}_2$ . Solvent systems other than alcohols and acetone may be equally acceptable.

In the chemical conversion of  $\text{CaO}$  to  $\text{CaCl}_2$ , the molten salt would be contacted with a strong chlorinating agent such as  $\text{HCl}$  or  $\text{COCl}_2$ . In this instance, the chlorinating agent converts the  $\text{CaO}$  to  $\text{CaCl}_2$  using the following equations:



An electrolytic method for removing  $\text{CaO}$  from  $\text{CaCl}_2$  was suggested by Barletta et al.<sup>17</sup> The salt is electrolyzed in a cell with a graphite-consumable anode. In operation, oxygen is removed at the anode when it reacts with carbon to form  $\text{CO}$  and  $\text{CO}_2$ . Calcium ions are reduced to metal at the cathode.

Thus, the electrolytic reduction reaction should be



As is the case in aluminum ER, the competing reacting should be the formation of CO gas,



In all cases the reactions are performed at about 800°C and therefore the oxygen-containing by-products (H<sub>2</sub>O and CO<sub>2</sub>) are driven off in the offgas stream.

None of the above systems have been demonstrated. There are serious drawbacks to all of them. In the case of physical separations, volatile organics are highly undesirable in a glove box system because of the potential for explosions and fire. In the chemical conversion system, HCl and COCl<sub>2</sub> pose serious corrosion problems, particularly at 800°C. An HCl system can probably be engineered without too much difficulty. A phosgene-handling system would be more difficult because of its greater reactivity. In the electrolytic system, corrosion should not be a serious problem. Its principal problem is design of the electrolytic cell.

Los Alamos is actively pursuing the direct reuse of CaCl<sub>2</sub> as a means of reducing both processing cost, and waste handling and disposal. Presently, all waste CaCl<sub>2</sub> is sent to retrievable storage with ultimate disposal in mind. The potential for reuse is large.

### C. Molten-Salt Extraction Salt Recycle and Electrorefining Salt Recycle

The goals in any salt recycle system are first, to keep the system as simple as possible, and second, to use compatible reagents for each of the steps: processing, recovery, and reprocessing. In evaluating potential recycle schemes, these two goals will play an important role.

The salt matrix presently used for both MSE and ER is an equal molar KCl-NaCl with MgCl<sub>2</sub> added as an oxidizing agent. After the operation, the salt contains these three compounds as well as PuCl<sub>3</sub> and AmCl<sub>3</sub>. During the stripping step, plutonium and americium are reduced to metal and removed from the salt as a metal button. The reducing agent presently used is calcium. The resulting salt, after stripping, is made up of KCl, NaCl, MgCl<sub>2</sub>, and CaCl<sub>2</sub>. Obviously, the salt composition becomes more and more complex. The specific make-up of the salt matrix is not significant as long as it is reasonably pure, absolutely dry, and

melts at less than 800°C. But, it is very desirable to know the specific characteristics of the salt being used from a chemistry and diagnostics standpoint.

The recycled salt will continually accumulate MgCl<sub>2</sub> and CaCl<sub>2</sub> with the CaCl<sub>2</sub> being the predominant compound. (The MgCl<sub>2</sub> may or may not be completely reduced to Mg<sup>0</sup> by Ca<sup>0</sup> and therefore a residual of MgCl<sub>2</sub> will probably be recycled in the return salt.) As a result of the CaCl<sub>2</sub> build-up, future investigations will involve using CaCl<sub>2</sub> instead of KCl·NaCl as the feed salt to MSE and ER.

Calcium metal is the usual reducing agent used in stripping plutonium and americium from these residue salts. Other active metals, such as sodium metal, show good potential for use as reducing agents. In the case of sodium metal, the reduction by-product would be NaCl according to the following reaction:



Because NaCl is already a major constituent of the initial salt matrix, the complexity of the salt does not change. This is highly desirable from a reprocessing standpoint.

These two approaches to salt recycle satisfy the needs to keep the system as simple as possible and to use compatible reagents in each step of the processing. The first approach involves changing matrix salt in order to be more compatible with the calcium-metal-reducing agent. The second approach involves changing the reducing agent to be compatible with the existing salt matrix. In both instances, the resulting salt matrix after the stripping step remains as simple as possible.

## VI. SUMMARY

### A. Processing Status

Plutonium pyrochemical processes are now the principal tools at Los Alamos for producing large amounts of high purity plutonium metal from impure metal and oxide scrap. Pyrochemical processing was selected because of the cost-effective means of handling material. The processes are highly compact and require little floor space and manpower to operate. The processes are also operationally efficient in that one or two steps can be used to supplant multistep operations found in the classical aqueous-chemistry flow streams. The third major cost impact is in the area of waste generation and reprocessing. In pyrochemical processing, nearly all residues have the potential for recycle. Very little primary

or secondary waste is generated. In the classical aqueous-process sequence, large volumes of liquids and some solids are usually generated in the reprocessing of waste materials. As a result of following the pyrochemical re-cycle route rather than the aqueous waste processing route, the plutonium values in the residues can be returned very expeditiously to the main process sequence. The form of the plutonium is as metal, which is most desirable from a production standpoint.

In order to achieve this goal of a fully integrated process sequence, a concerted research and process development effort must take place. Present R&D efforts are devoted to the development of a cost-effective pyrochemical process for the recycle of plutonium in residues. Future efforts will be aimed at the recycle of reagents in each individual process. The objectives of the recycle are to produce plutonium metal, which can be further purified, and to generate small volumes of residues, which can be discarded or recycled.

#### B. The Future Process Goal

The goal of any chemical production operation is to generate a high-quality product while rejecting a small volume of ultimate waste. The bulk of the process reagents are then recycled to make optimum use of them. With this thought in mind, the future processing goal for the Plutonium Processing Facility is to establish a fully integrated pyrochemical system, similar in design to that in Fig. 12. Only two ultimate waste streams would be generated. One waste stream would contain the "noble" impurities and the second would contain the more "active" impurities. All reagents would be regenerated and/or recycled. The simplest systems would be used, meaning that probably a single solvent salt with a single compatible reducing agent would be used in every process.

#### REFERENCES

1. L. J. Mullins, A. N. Morgan, S. A. Apgar, and D. C. Christensen, "Six-kilogram Scale Electrorefining of Plutonium Metal," Los Alamos National Laboratory, LA-9469-MS (April 1982).
2. L. J. Mullins and C. L. Foxx, "Direct Reduction of  $^{238}\text{PuO}_2$  and  $^{239}\text{PuO}_2$  to Metal." Los Alamos National Laboratory report LA-9073 (February 1982).
3. L. J. Mullins, D. C. Christensen, and B. R. Babcock, "Fused Salt Processing of Impure Plutonium Dioxide to High-Purity Metal," Los Alamos National Laboratory report LA-9154-MS (January 1982).
4. R. D. Baker, "Preparation of Plutonium Metal by the Bomb Method," Los Alamos Scientific Laboratory report LA-473 (May 1946).

5. J. M. Cleveland, The Chemistry of Plutonium (Gordon and Breach Science Publishers, New York, 1970).
6. C. L. Sohn, C. Thorn, and D. C. Christensen, "Enhanced Production of Plutonium Metal Using  $\text{PuO}_2$  in the  $\text{PuF}_4$ /Bomb Reduction Process," Los Alamos National Laboratory document LA-UR-82-1230 (May 1982).
7. L. J. Mullins, J. A. Leary, and W. J. Maraman, "Removal of Fission Product Elements by Slagging," Ind. Eng. Chem. 52, 227-230 (1960).
8. J. B. Knighton, R. G. Auge, J. W. Berry, "Molten Salt Extraction of Americium from Molten Plutonium Metal," Rockwell International Rocky Flats Plant, RFP-2365 (March 12, 1976).
9. L. J. Mullins and A. N. Morgan, "A Review of Operating Experience at the Los Alamos Plutonium Electrorefining Facility, 1963-1977," Los Alamos National Laboratory report LA 8943 (December 1981).
10. D. C. Christensen and J. A. Rayburn, "Pyrochemical Recovery of Plutonium Fluoride Reduction Slag," to be published.
11. D. C. Christensen and L. J. Mullins, "Salt Stripping, A Pyrochemical Approach to the Recovery of Plutonium Electrorefining Salt Residues," Los Alamos National Laboratory document LA-UR-82-1220 (May 1982).
12. J. W. Berry, J. B. Knighton, and C. A. Hammel, "Vacuum Distillation of Americium Metal," Rockwell Int., Energy Systems Group, Rocky Flats Plant report RFP 3211 (January 22, 1982).
13. J. B. Knighton and R. K. Steunenberg, "Preparation of Metals By Magnesium-Zinc Reduction, Part II, Reduction of Plutonium Dioxide," Argonne National Laboratory report ANL-7059 (June 1965).
14. J. G. Reavis and J. A. Leary, "Non-Aqueous Dissolution of Massive Plutonium," U. S. Patent Number 2 886 410 (May 12, 1959).
15. J. G. Reavis, J. A. Leary, and W. J. Maraman, "Method for Obtaining Plutonium Metal from its Trichloride," U. S. Patent Number 3 049 423 (August 14, 1962).
16. J. B. Knighton, R. G. Auge, and G. D. Bird, "Purification of Plutonium Metal by the Pyroredox Process," Rockwell Int., Rocky Flats Plant report CRD 80-043 (February 1981).
17. R. E. Barletta, L. J. Jardine, T. J. Gerding, D. K. Kroeck, and M. Krumpelt, "Molten Salt Recycle, Electrolysis of  $\text{CaO}$  in Molten Salt," Argonne National Laboratory report ANL 79-99.

Printed in the United States of America  
Available from  
National Technical Information Service  
US Department of Commerce  
5285 Port Royal Road  
Springfield, VA 22161

Microfiche (A01)

<u>Page Range</u>	<u>NTIS Price Code</u>	<u>Page Range</u>	<u>NTIS Price Code</u>	<u>Page Range</u>	<u>NTIS Price Code</u>	<u>Page Range</u>	<u>NTIS Price Code</u>
001-025	A02	151-175	A08	301-325	A14	451-475	A20
026-050	A03	176-200	A09	326-350	A15	476-500	A21
051-075	A04	201-225	A10	351-375	A16	501-525	A22
076-100	A05	226-250	A11	376-400	A17	526-550	A23
101-125	A06	251-275	A12	401-425	A18	551-575	A24
126-150	A07	276-300	A13	426-450	A19	576-600	A25
						601-up*	A99

\*Contact NTIS for a price quote.

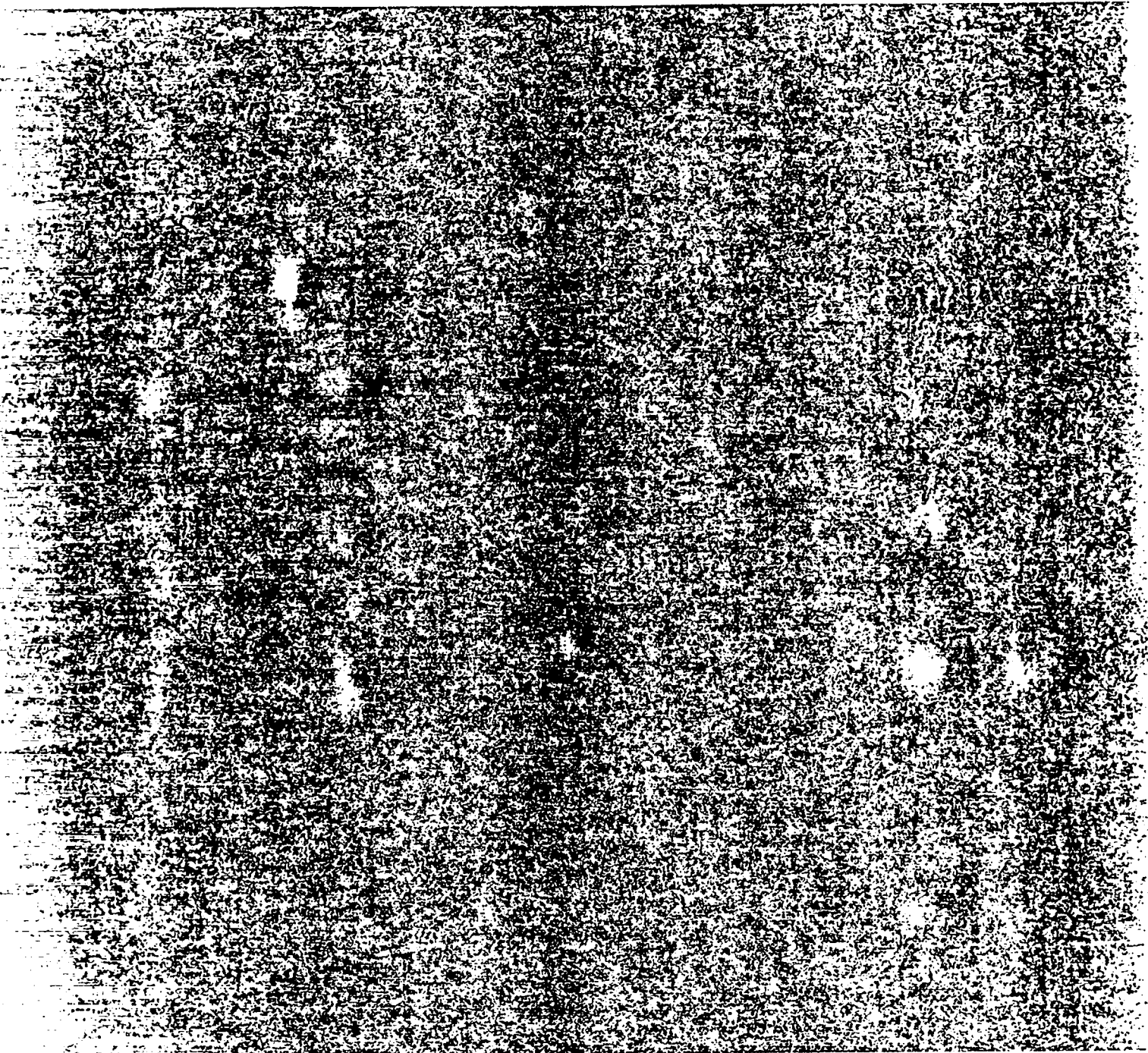

Los Alamos